

# Circulating current battery heater

Cyrus N. Ashtiani

Thomas A. Stuart

Follow this and additional works at: <http://utdr.utoledo.edu/utpatents>

---

This Patent is brought to you for free and open access by the Technology Transfer Office at The University of Toledo Digital Repository. It has been accepted for inclusion in University of Toledo U.S. Patents by an authorized administrator of The University of Toledo Digital Repository. For more information, please see the repository's [About page](#).



(54) **CIRCULATING CURRENT BATTERY HEATER**

(75) Inventors: **Cyrus N. Ashtiani**, West Bloomfield, MI (US); **Thomas A. Stuart**, Toledo, OH (US)

(73) Assignees: **DaimlerChrysler Corporation**, Auburn Hills, MI (US); **University of Toledo**, Toledo, OH (US)

(\*) Notice: Subject to any disclaimer, the term of this patent is extended or adjusted under 35 U.S.C. 154(b) by 0 days.

(21) Appl. No.: **09/400,779**

(22) Filed: **Sep. 22, 1999**

**Related U.S. Application Data**

(63) Continuation-in-part of application No. 09/070,331, filed on Apr. 30, 1998, now Pat. No. 5,990,661.

(51) **Int. Cl.**<sup>7</sup> ..... **H01M 10/46**

(52) **U.S. Cl.** ..... **320/128**

(58) **Field of Search** ..... 320/118, 121, 320/127, 128, 139, 145, 153

(56) **References Cited**

**U.S. PATENT DOCUMENTS**

- 3,767,995 10/1973 Kaminski et al. .
- 4,194,146 3/1980 Patry et al. .
- 4,209,736 6/1980 Reidenbach .
- 5,479,083 \* 12/1995 Brainard .
- 5,504,415 4/1996 Podrazhansky et al. .
- 5,610,495 3/1997 Yee et al. .
- 5,631,534 \* 5/1997 Lewis ..... 320/118 X
- 5,659,237 8/1997 Divan et al. .
- 5,684,683 11/1997 Divan et al. .
- 5,710,504 \* 1/1998 Pascual et al. .... 320/118 X

- 5,760,488 6/1998 Sonntag .
- 5,781,419 7/1998 Kutkut et al. .
- 5,808,469 9/1998 Kopera .
- 5,814,970 \* 9/1998 Schmidt et al. .... 320/118
- 5,821,729 \* 10/1998 Schmidt et al. .... 320/118 X
- 5,824,432 10/1998 Currie .
- 5,828,201 10/1998 Hoffman, Jr. et al. .
- 5,831,514 11/1998 Hilpert et al. .
- 5,869,950 2/1999 Hoffman, Jr. et al. .
- 5,910,722 6/1999 Lyons et al. .
- 6,072,301 \* 6/2000 Astiani et al. .

\* cited by examiner

*Primary Examiner*—Edward H. Tso

(74) *Attorney, Agent, or Firm*—Mark P. Calcaterra

(57) **ABSTRACT**

A circuit for heating energy storage devices such as batteries is provided. The circuit includes a pair of switches connected in a half-bridge configuration. Unidirectional current conduction devices are connected in parallel with each switch. A series resonant element for storing energy is connected from the energy storage device to the pair of switches. An energy storage device for intermediate storage of energy is connected in a loop with the series resonant element and one of the switches. The energy storage device which is being heated is connected in a loop with the series resonant element and the other switch. Energy from the heated energy storage device is transferred to the switched network and then recirculated back to the battery. The flow of energy through the battery causes internal power dissipation due to electrical to chemical conversion inefficiencies. The dissipated power causes the internal temperature of the battery to increase. Higher internal temperatures expand the cold temperature operating range and energy capacity utilization of the battery. As disclosed, either fixed frequency or variable frequency modulation schemes may be used to control the network.

**6 Claims, 2 Drawing Sheets**

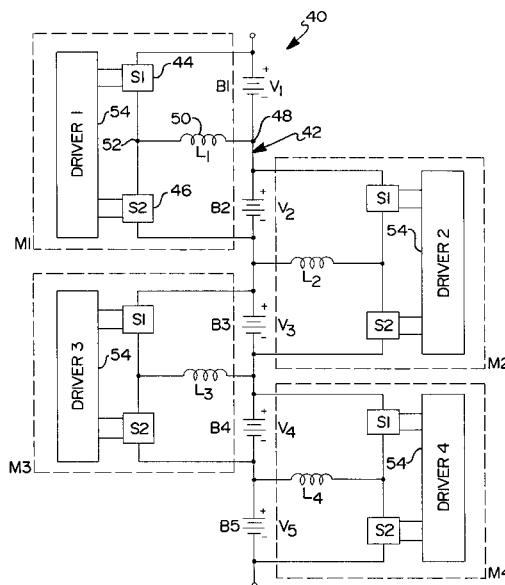

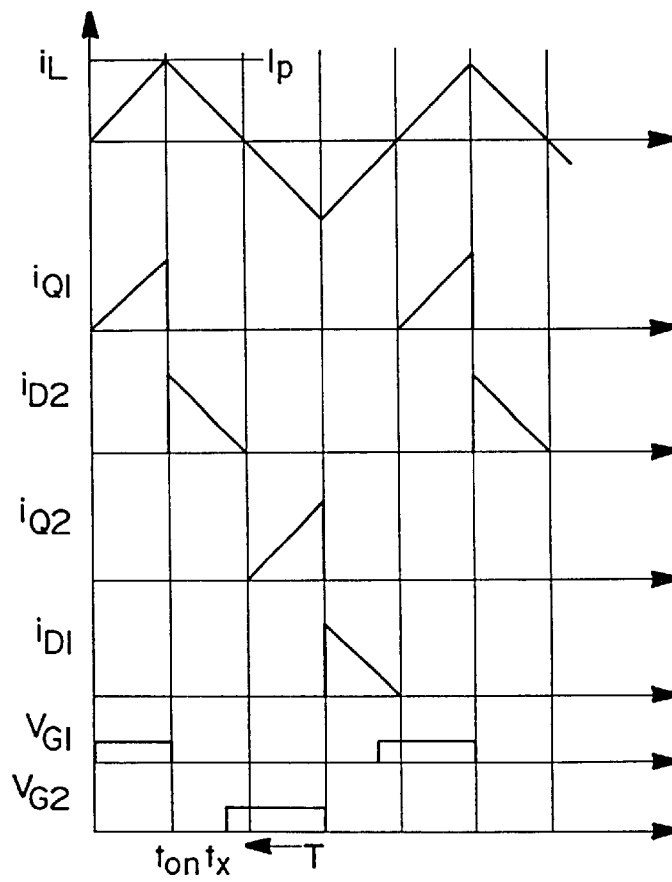
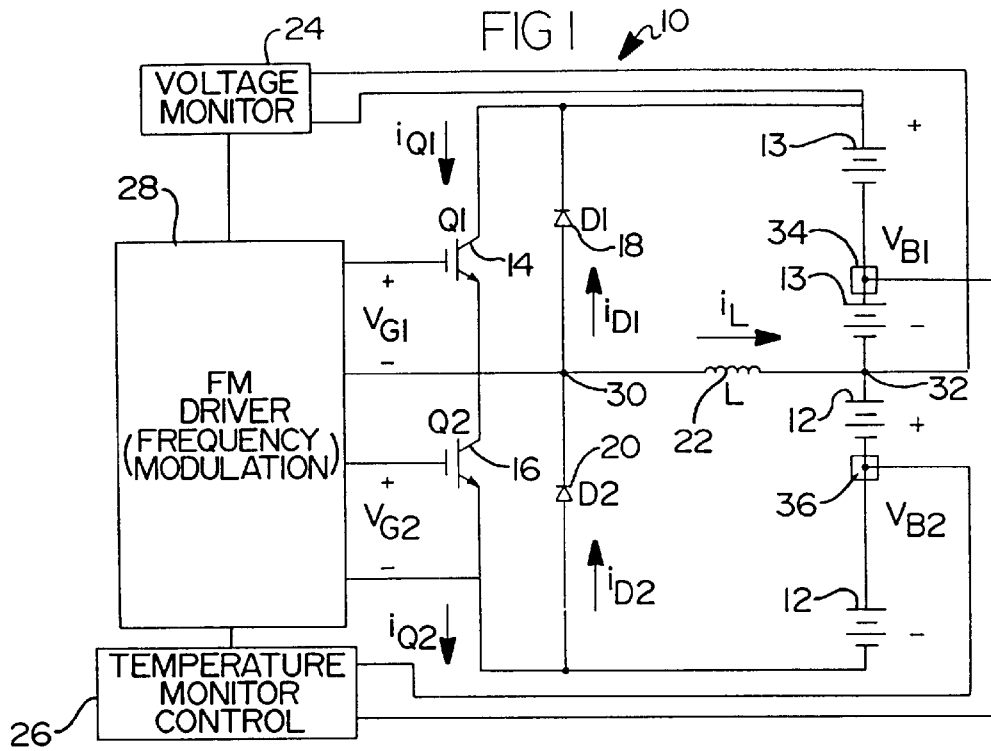
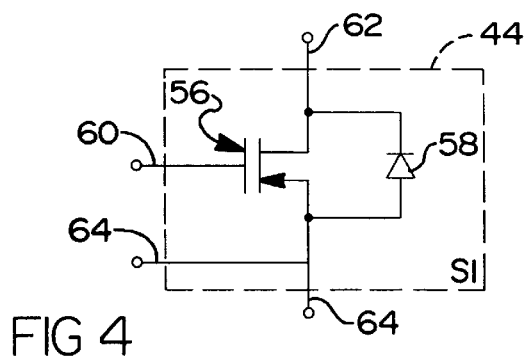
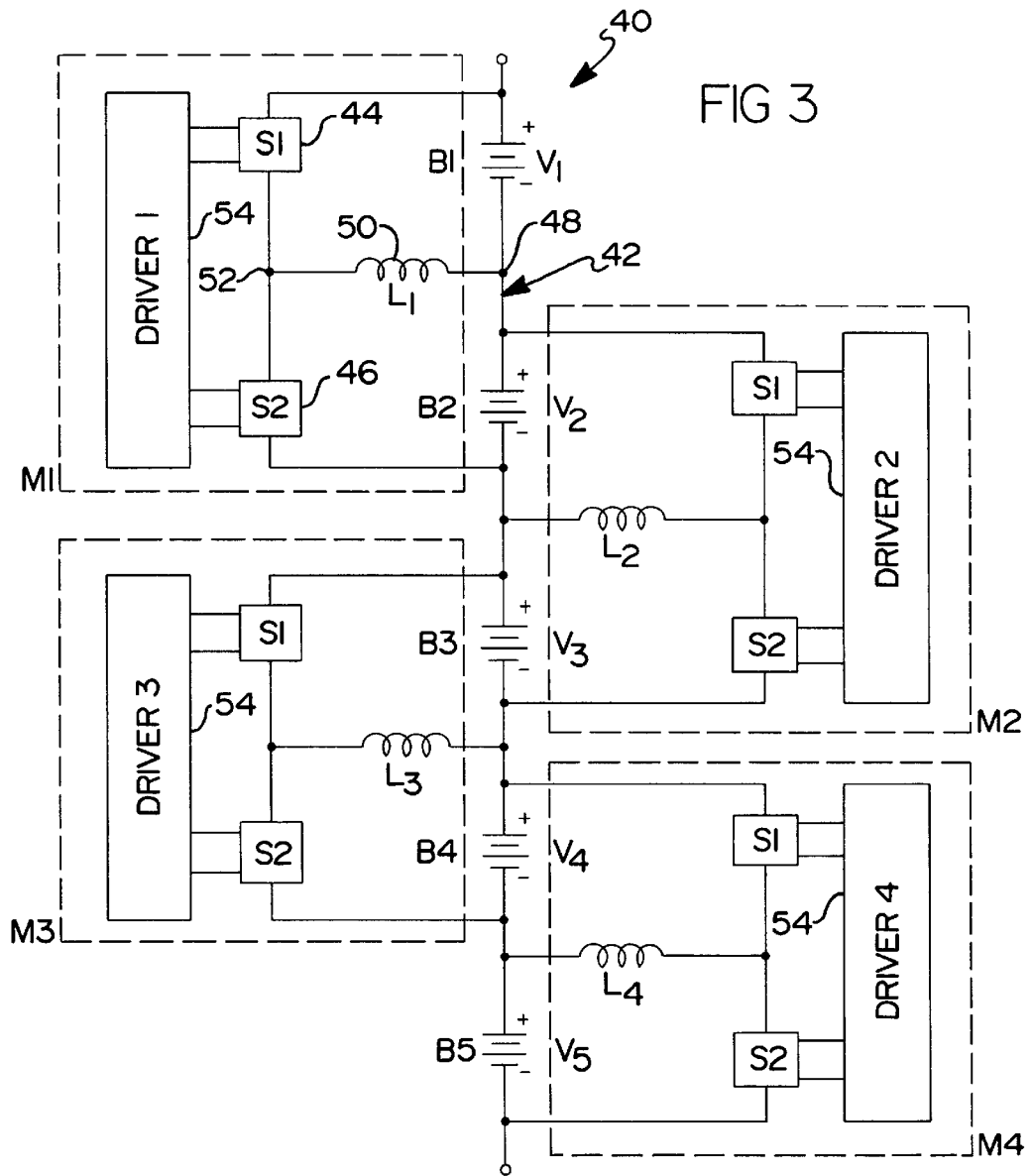

FIG 2



## CIRCULATING CURRENT BATTERY HEATER

### CROSS-REFERENCE TO RELATED APPLICATION

This is a continuation-in-part of United States patent application Ser. No. 09/070,331, filed Apr. 30, 1998, now U.S. Pat. No. 5,990,661.

### STATEMENT REGARDING FEDERALLY SPONSORED RESEARCH OR DEVELOPMENT

This invention was made with Government support under NREL subcontract number ZAN-6-16334-01, prime contract number DE-AC36-83CH10093 issued by the Department of Energy. The government has certain rights in this invention.

### BACKGROUND AND SUMMARY OF THE INVENTION

The present invention relates generally to devices for heating batteries. More particularly, the invention relates to electrical circuits for using the stored energy of a battery to heat either the connected battery or a peripheral battery. The invention also relates to electrical circuits for transferring energy between a plurality of series connected batteries and equalizing the energy within the batteries.

With the current growth in electrical and electronic technology, there is a growing interest in using batteries as a primary source of power, for backup applications, and for starter, lighting, ignition (SLI) applications. Electric vehicles, hybrid vehicles, military electronic systems, consumer vehicles, communications systems, medical emergency equipment, and handheld power tools are among the more promising applications requiring batteries.

Batteries provide a uniquely portable source of energy that is not dependent on a connection to a power grid. However, the operation of a battery is limited by a number of factors, one of which is temperature. At low temperatures the capacity of a battery to store energy, the maximum value of discharge current which can be drawn from the battery, and the cold cranking amps capability decrease substantially. Many applications require batteries either as a primary power source, such as; electric vehicles, hybrid vehicles, and handheld power tools, or as; a backup power source such as communications systems, medical emergency equipment, and military electronic systems, or also as; an SLI source such as commercial vehicles. Batteries used for SLI applications at cold temperatures additionally must be capable of supplying greater amounts of cold cranking current to overcome the increased engine resistance caused by decreased engine oil viscosity at low temperatures. Most if not all of these devices are exposed to outdoor environments and therefor must be able to operate at low temperatures.

Current methods of operating batteries at low temperatures employ means for heating the battery from an external source, such as warm air heating, liquid heating, and thermal jackets. Conventional battery heating systems typically use a separate power source to power a heating element which generates the required heat. The resultant heat is then transferred to the battery by either a convection system or a conduction system. Convection systems blow hot air across the battery, whereas conduction systems apply heat directly to the surface of the battery. Each of these systems warm the battery by heating the external surface of the battery. By applying heat to the external surface a significant amount of

the generated heat is lost to the external environment. Both convection and conduction systems additionally require some form of mechanical structure co-located with the battery. Also, warm air heating and liquid heating require complex mechanical systems that use substantial amounts of external power. These constraints limit the portability of batteries and demand the availability of an external power source.

A system employing thermal jackets typically includes a flexible insulator that wraps around the exterior of a battery. On the inner surface of the insulator is an externally powered heating element. While thermal jackets do not require a complex mechanical system, extra space around the individual batteries must be set aside. Additionally, the thermal jacket systems known in the art must be powered by a separate power source or power grid. While heating systems and thermal jackets can be used to extend the ambient temperature range within which batteries can be operated, they have not proven capable of efficiently heating a battery without an external power source and bulky external mechanical attachments.

Accordingly, it is desirable to overcome the disadvantages associated with the prior art systems. The present invention addresses this problem by circulating energy from within the battery into lossless or nearly lossless energy storage devices and then back into the battery causing the battery to dissipate power internally due to the electrical-to-chemical energy conversion losses and conduction losses of the battery. The internally dissipated power heats the battery, causing the internal temperature to rise. A higher internal temperature increases the operating temperature range, improves the cold cranking amps capability, and improves the energy capacity utilization of the battery. The circuit of the present invention does not require a complex mechanical structure, and efficiently heats the battery from the inside out. The circuit enhances the portability of batteries into cooler operating environments by using the internal energy of the battery for self-heating. The circuit takes energy from the battery and stores it in an essentially lossless element and then recirculates that energy back into the battery. In transferring energy first out of the battery and then back into the battery some losses will occur within the battery due to inefficiencies in converting electrical energy into chemical energy. The losses result in increased heat within the battery thereby causing the battery to heat from the inside out. Additionally, there are very few constraints on the location of the circuit relative to the battery. It is possible to place the circuit a significant distance away from the battery, depending on the magnitude of the circulating current. Additionally the circuit of the present invention allows the energy potential within the individual cells of an energy storage device to be equalized.

### BRIEF DESCRIPTION OF THE DRAWINGS

For a more complete understanding of the invention, its objects and advantages, reference may be had to the following specification and to the accompanying drawings in which:

FIG. 1 is a schematic diagram showing a preferred embodiment of the invention;

FIG. 2 is a signal diagram showing the current and voltage waveforms associated with a preferred embodiment of the present invention;

FIG. 3 is a schematic diagram showing an alternate preferred embodiment of the invention used for battery voltage equalization; and

FIG. 4 is an isolated schematic diagram of the switching circuit used in accordance with the preferred embodiments of the present invention.

#### DETAILED DESCRIPTION OF THE PREFERRED EMBODIMENTS

Referring to FIG. 1, an exemplary circulating current battery heater circuit 10 according to the teachings of the present invention is shown. The present implementation of circuit 10 is a variable frequency half-bridge configuration operating at a frequency less than 25 KHz. The circuit 10 heats a string of Li-Ion batteries 12, 13 having a combined voltage of 144 volts. Other types of batteries including but not limited to; lead-acid, NiCad, NiMH, alkaline, and lithium batteries are within the scope of the present invention. Additionally, either one or more batteries 12, 13 may be heated, such as batteries units ranging from a 12 volt car starter battery to 600 volt battery assemblies for electric cars or buses. Although the preferred embodiment employs a variable frequency modulation (FM) technique, the principles of the invention may equally be extended to the constant frequency pulse-width modulation technique. The circuit 10 should be operated over a frequency range that minimizes the inductor weight and size without creating excessive overall losses in the inductor core, coil, and switching losses of the power semiconductor switches.

The presently preferred embodiment includes a pair of Insulated Gate Bipolar Transistors (IGBTs) 14 and 16 connected in a half-bridge configuration. However, the principles of the invention may be extended to the use of other switching devices such as; MOSFET's, BJT's, and MCT's. Anti-parallel diodes 18 and 20 are connected in parallel with IGBTs 14 and 16 respectively. Inductor 22 is connected from the junction 30 of IGBTs 14 and 16 to the junction 32 of the energy storage means (or upper string of batteries) 13 and the lower string of batteries 12. Although an inductor is used for the series resonant element in the preferred embodiment, a series LC combination is also within the scope of the invention.

The energy storage means 13 in the present embodiment is preferably a string of batteries equivalent in voltage to the lower string of batteries 12. However, the energy storage means may also include other energy storage devices such as various types of capacitors including; ceramic, MLC, plastic film, plastic foil, oil-filled, aluminum electrolytic, and tantalum electrolytic capacitors. A voltage monitor 24 is provided for sensing voltage across each string of batteries 12 and 13. A temperature monitor control 26 is provided for sensing the temperature of each of the batteries via temperature sensors 34 and 36 associated with each string of batteries 12 and 13. The invention also encompasses potentially monitoring the circulating current and charge in batteries 12 and 13. Current monitoring may be accomplished by use of a Hall effect circuit or a resistive shunt in series with inductor 22. Driving an integrator circuit in a feedback loop with a sensed current signal would provide battery charge and current monitoring and control. Both current and charge monitor and control circuits are well known in the art. The outputs of the voltage monitor 24 and the temperature monitor control 26 connect to FM driver 28 which may also function as the system controller. A battery undervoltage or overtemperature condition will be sensed by the monitor circuits 24, 26 which will disable FM driver 28, thereby protecting the battery from a potentially destructive operating condition. The two outputs of FM driver 28 connect from gate to emitter on each of the IGBTs 14 and 16.

In operation, the preferred embodiment employs frequency modulation with variable frequency with a maxi-

imum value of 25 kilohertz. However, the principles of the invention may be readily extended to a circuit employing pulse-width modulation. As is known in the art, pulse-width modulators control a circuit by operating at a fixed frequency and varying the pulse-width in response to a controlling input. A frequency modulator controls a circuit by varying the total period of the signal.

Referring to FIGS. 1 and 2, the  $V_{G1}$  output from FM driver 28 drives transistor Q1 14 into the ON state. Voltage from energy storage means 13 is impressed across inductor 22 causing current  $i_L$  to linearly increase with time, storing energy within inductor 22. At time  $t_{ON}$  (FIG. 2) FM driver 28 drives the  $V_{G1}$  signal into the low state. As Q1 14 begins to turn off the current which flows through inductor 22 will begin to conduct through lower battery 12 and up through anti-parallel diode 20. Voltage from the batteries 12 is impressed across inductor 22 causing current  $i_L$  to linearly decrease. During this mode of operation energy is transferred from inductor 22 to lower string of batteries 12.

As energy is either transferred into or out of the strings of batteries 12 and 13, conduction losses and electrical-to-chemical conversion inefficiencies cause power to be dissipated within the batteries. The dissipated power causes the internal temperature of the batteries to rise resulting in very efficient self-heating of the batteries.

At time  $t_x$  the FM driver 28 drives the  $V_{G2}$  output high, turning on transistor Q2 16. Turning on Q2 16 while current continues to flow through anti-parallel diode 20 results in virtually zero turn-on losses in Q2 16. The turn-on losses of an IGBT are directly proportional to the square of the voltage from collector to emitter. Normally, with most modulation schemes the voltage from collector to emitter at turn-on would be approximately 72 volts in this circuit configuration. However, by turning on IGBT 16 while current is flowing in anti-parallel diode 20, the voltage impressed from collector to emitter at turn-on is approximately one diode drop. A diode drop for a high voltage diode is approximately one or two volts. Therefore, turn-on losses are decreased by more than a factor of 5,000.

Current in anti-parallel diode 20 continues to decrease until it reaches zero amps, at which time  $i_L$  begins to flow into the collector of Q2 16 and up through lower batteries 12. As current flows from batteries 12 through inductor 22 energy is transferred from the string of batteries 12 into inductor 22 until Q2 16 turns off. At time T the FM driver 28 drives the  $V_{G2}$  output to the low state turning off Q2 16. As Q2 16 turns off, the current flowing through inductor 22 begins to flow up through anti-parallel diode 18 and down through the upper string of batteries 13. The voltage from batteries 13 is impressed across inductor 22 causing current  $i_L$  to begin to linearly increase. During this period, energy is transferred from inductor 22 into upper string of batteries 13. At some time prior to inductor current  $i_L$  reaching zero, Q1 14 is turned on, thereby attaining virtually lossless turn-on in a manner similar to transistor Q2 16. When current through inductor 22 reaches zero amps, anti-parallel diode 18 becomes back-biased and the current once again begins to flow through the loop comprising IGBT 14, inductor 22, and upper string of batteries 13.

Turning now to FIGS. 3 and 4, equalization circuit 40 is disclosed in accordance with an alternate preferred embodiment of the present invention. As shown, equalization circuit 40 comprises four switching modules M1, M2, M3 and M4 which are connected to a battery pack 42. The battery pack 42 includes five series connected energy storage cells B1, B2, B3, B4 and B5. While battery pack 42 is shown to

include five cells, one skilled in the art will appreciate that equalization circuit 40 can be used with any type of battery pack having a plurality of cells. Each switching module is substantially similar to the switching components of circuit 10 shown in FIG. 1. Each switching module M1, M2, M3, M4 includes a first switch S1 44 connected generally across a first storage cell such as cell B1, and a second switch S2 46 is connected generally across a second storage cell such as cell B2. As shown, each switching module overlaps a storage cell with another switching module. In the typical configuration, the number of switching modules will be one less than the number of energy storage cells.

An inductor 50 or similar type of temporary energy storage device is connected to a node 48 between storage cells B1 and B2, and connected to a node 52 between first and second switches 44, 46 as shown. Inductor 50 can be any type of inductor suited for the particular application. Within each switching module, a suitable driver circuit 54 is connected to first switch 44 and connected to second switch 46. The driver circuit 54 may be any of the driver circuits described above with respect to FIG. 1. While the components of switching module M1 are described in detail, the components of the other switching modules M2, M3 and M4 are identical to switching module M1.

The components forming first switch 44 are shown in detail in FIG. 4. It should be understood that second switch 46 includes components which are substantially similar to the components of first switch 44. More specifically, each first and second switch 44, 46 includes a transistor 56, and an anti-parallel diode 58 connected in parallel with the transistor 56. The cathode of diode 58 is connected to the transistor drain 62, and the anode of diode 58 is connected to the transistor source 64. The gate 60 and source 64 of transistor 56 are connected to the driver circuit 54. Preferably, transistor 56 is a field effect transistor (FET). However, one skilled in the art will readily appreciate that a variety of transistors may be employed depending upon the specific application for equalization circuit 40. The switching modules M1-M4 shown in FIG. 3 are identical to the circuit external to the batteries, shown in FIG. 1, except that the voltage monitor 24 and the temperature monitor 26 have been omitted, and the IGBT's have been replaced with FETs because the voltages associated with battery pack 42 are preferably lower.

In operation, each switching module M1, M2, M3, M4 is responsible for transferring energy between adjacent storage cells. For example switching module M1 transfers energy between storage cells B1 and B2, and switching module M2 transfers energy between storage cells B2 and B3. The remaining switching modules M3, M4 operate in a similar fashion with storage cells B3-B5. As a result, the purpose of switching modules M1-M4 is to equalize the energy potentials or voltages of battery cells B1-B5.

As part of normal operation, the voltages  $V_1-V_5$  tend to become unbalanced during charge and discharge due to slight variations among the individual storage cells B1-B5. Since the batteries B1-B5 have high and low voltage limits, the highest will limit charging, and the lowest will limit discharge. Maximum charge capacity is achieved when the voltages of each of the batteries B1-B5 are equal.

As part of the operational example presented herein, assume that the voltage  $V_2$  of battery B2 is lower than the voltage  $V_1$  of battery B1. Switching module M1 will transfer charge from B1 to B2 as follows. When transistor Q1 56 (of switch S1) is turned on by driver circuit 54 and conducts, energy from battery  $B1=E_1=0.5L_1I_{Q1}^2$  (peak) is removed

from battery B1 and stored within the inductor 50. When transistor Q1 (of switch S1) is turned off by driver circuit 54, this energy is transferred to battery B2 via diode D2 (of switch S2). Transistor Q2 (of switch S2) is then turned on by driver circuit 54 and conducts energy in a similar fashion for storing energy from battery B2 within the inductor 50. After transistor Q2 is turned off by driver circuit 54 and finishes conducting, energy from battery  $B2=E_2=0.5L_1I_{Q2}^2$  (peak) is transferred back to battery B1 via diode D1 58 (of switch S1). However, since  $V_1>V_2$ , this means  $I_{Q1(peak)}>I_{Q2(peak)}$  and  $E_1>E_2$ , i.e. there is a net energy transfer,  $E_1-E_2$  from battery B1 to battery B2. This also means that on each cycle there will be a net charge transfer from B1 to B2 until the voltages  $V_1$  and  $V_2$  become equal.

In a similar manner switching module M2 equalizes batteries B2 and B3; switching module M3 equalizes batteries B3 and B4; and switching module M4 equalizes batteries B4 and B5. No matter how the initial voltage imbalances are distributed, energy will be transferred between batteries until all voltages are equal. When complete equalization is realized, the driver circuits 54 can be turned off.

More efficient strategies can be used if a microprocessor, or any type of computer (not shown) is implemented to measure the voltages  $V_1-V_5$  and to control the switches S1 44 and S2 46 in modules M1-M4. For example, if the microprocessor determines that  $V_1$  is the highest voltage and  $V_3$  is the lowest voltage, the switches can transfer energy from  $V_1$  to  $V_3$  as follows.

1. Close the S1 transistor of switching module M1 to transfer energy from battery B1 to inductor L1 50.
2. Open the S1 transistor of switching module M1 to transfer energy from inductor L1 to battery B2 via the diode in S2 (the S2 transistor remains off).
3. Close the S1 transistor of switching module M2 to transfer energy to from battery B2 to inductor L2.
4. Open the S1 transistor of switching module M2 to transfer energy from the inductor L2 to battery B3 via the diode in S2 of switching module M2.

The operation is similar for any pair of highest and lowest voltages, and this pair may change as operation proceeds. The microprocessor continuously changes the switch operations so that energy is always being transferred from the present highest to the present lowest voltage. This second method is more efficient because energy is transferred in only one direction, whereas in the first method a large part of the energy was first removed from each battery and then returned to the same battery.

From the foregoing it will be understood that the invention provides a circuit that employs a low loss network for using the internal energy of a battery to heat either the same battery or another battery. The invention also provides a circuit for equalizing the voltage potential of the cells within a battery pack. The circuit may be readily scaled by selection of appropriate switching devices and energy storage devices to accommodate different quantities of batteries, different types of batteries, and different methods of storing the intermediate energy. The circuit thus provides a novel and efficient means for heating batteries in a wide range of applications.

Through the use of a low loss switched energy storage network, the invention can provide a means of increasing the effective operating temperature range of batteries and improving the utilization of the energy stored within batteries operating within low temperature environments. Additionally the invention improves the low temperature charg-

ing efficiency of a battery. The circuit enhances the portability of systems that employ batteries by providing means for using energy stored within the battery to self heat the battery. The invention is therefore ideally suited for heating electric vehicle battery assemblies, as well as batteries used with hand held power tools. The circuit will heat both multiple batteries and single batteries using either variable frequency modulation or pulse-width modulation.

While the invention has been described in its presently preferred embodiment, it will be understood that the invention is capable of certain modifications and change without departing from the spirit and scope of the invention as set forth in appended claims.

What is claimed is:

- 1. A circuit for heating an energy storage device comprising:
  - a first switching device connected to the energy storage device;
  - a second switching device connected to the energy storage device; and
  - an inductor disposed between the first and second switching devices;
  - wherein the first and second switching devices each include a transistor connected to the energy storage device and connected to the inductor and the first and second switching devices each include a diode connected in parallel with the transistor.
- 2. A device for circulating energy for performing a heating function comprising:
  - an energy storage device comprising a plurality of energy storage cells;
  - a first switching circuit connected to the energy storage device;
  - a second switching circuit connected to the energy storage device; and
  - an inductor connected between the first and second switching circuits;
  - wherein the first and second switching circuits are alternately switched between a current conducting state and a non-conducting state for transferring energy back and forth between the energy device and the inductor;
  - wherein the first and second switching circuits each include a transistor connected to the energy storage device and connected to the inductor and the first and second switching circuits each include a diode connected in parallel with the transistor.
- 3. A device for equalizing the energy potential within the cells of an energy storage device comprising:
  - at least a first storage cell and a second storage cell contained within the energy storage device;
  - a first switching circuit connected across the first storage cell;
  - a second switching circuit connected across the second storage cell; and
  - an inductor connected between the first and second switching circuits;
  - the first and second switching circuits being alternately switched between a current conducting state and a non-conducting state for transferring energy between the first storage cell, the inductor, and the second

storage cell, wherein the first and second switching circuits are alternately switched until a net energy transferred between the first storage cell and the second storage cell approaches zero;

wherein the first and second switching circuits each include a transistor connected to the energy storage device and connected to the inductor and the first and second switching circuits each include a diode connected in parallel with the transistor.

- 4. A circuit for heating an energy storage device comprising:
  - a first switching device connected to the energy storage device;
  - a second switching device connected to the energy storage device;
  - an inductor disposed between the first and second switching devices; and
  - a frequency modulation circuit for alternately switching the first and second switching devices between a conducting state and a non-conducting state.
- 5. A device for circulating energy for performing a heating function comprising:
  - an energy storage device comprising a plurality of energy storage cells;
  - a first switching circuit connected to the energy storage device;
  - a second switching circuit connected to the energy storage device; and
  - an inductor connected between the first and second switching circuits;
  - wherein the first and second switching circuits are alternately switched between a current conducting state and a non-conducting state for transferring energy back and forth between the energy device and the inductor; and
  - a frequency modulation circuit for alternately switching the first and second switching circuits between a conducting state and a non-conducting state.
- 6. A device for equalizing the energy potential within the cells of an energy storage device comprising:
  - at least a first storage cell and a second storage cell contained within the energy storage device;
  - a first switching circuit connected across the first storage cell;
  - a second switching circuit connected across the second storage cell; and
  - an inductor connected between the first and second switching circuits;
  - the first and second switching circuits being alternately switched between a current conducting state and a non-conducting state for transferring energy between the first storage cell, the inductor, and the second storage cell, wherein the first and second switching circuits are alternately switched until a net energy transferred between the first storage cell and the second storage cell approaches zero;
  - a frequency modulation circuit for alternately switching the first and second switching circuits between a conducting state and a non-conducting state.